

Vacumat Eco G4 Remote

that's excellence.



ENG Installation and operating manual

Inhoudsopgave

1. Liability	4
2. Warranty	5
3. Copyright	6
4. General safety instructions	7
4.1. Warning symbols in this manual	7
4.2. Purpose and use of this manual	8
4.3. Qualifications required, assumptions	8
4.4. Staff qualification	9
4.5. Appropriate use	9
4.6. Incoming goods	10
4.7. Transportation, storage, unpacking	10
4.8. Operations room	10
4.9. Noise reduction	11
4.10. Emergency - STOP/ Emergency - OFF	11
4.11. Personal protective equipment (PPE)	12
4.12. Exceeding permitted pressure/temperature levels	12
4.13. System water	12
4.14. Safeguards	13
4.15. External forces	13
4.16. Inspection prior to commissioning, maintenance and re-inspection	14
4.17. Operating insurance inspections	14
4.18. Electrical equipment inspections, routine inspection	14
4.19. Maintenance and repairs	15
4.20. Obvious misuse	15
4.21. Other hazards	15
5. Product description	16
5.1. Operating principle	16
5.2. System diagram	18
5.3. Component parts, vessels and connection assembly	19
5.4. Mode of operation	20
5.5. Top-up	21
5.6. Pressure-controlled top-up	21
5.7. Level-controlled or externally-controlled top-up (for active pressure maintenance)	

	21
5.8. Top-up OFF	21
5.9. Operating mode - fully automatic	21
5.10. Standby operating mode	22
5.11. Break times / exclusion times with blocking intervals	22
5.12. Vacuum test	23
5.13. Manual mode	24
5.14. Connectivity options	24
5.15. Markings	25
5.16. Control unit	26
6. Assembly	29
6.1. Installing, levelling, bolting - Ensure stability!	29
6.2. Connecting the pipework	29
6.3. Connecting the electrical supply	30
7. Commissioning	32
7.1. Initial commissioning	32
7.2. Settings / control actions	33
7.3. Recommissioning	34
8. Maintenance	35
8.1. Malfunction messages	36
9. Appendix 1: Technical data, general specifications	40
9.1. Ambient conditions	40
9.2. Installation examples	40
9.3. Minimum distances: clearance for service and repair	42
10. Appendix 2: technical data and specifications	43
11. Appendix 3: Flamconnect & remote portal	45
12. Appendix 4: Optional accessories and their integration	47
12.1. System separation by top-up unit (NFE)	47
12.2. Top-up from a system separator vessel	47
13. Appendix 5: MeiFlow L MF Connector kit	48
14. Appendix 6: Declaration of Conformity	49

1. Liability

All technical specifications, data and instructions for executable actions and actions that must be executed contained herein are correct at time of publication. This information is the result of our current findings and experience to the best of our knowledge. We reserve the right to make technical changes subject to the future development of the Flamco product referred to in this publication. Hence no rights may be derived from technical data, descriptions and illustrations. Technical pictures, drawings and graphs do not necessarily correspond to the actual assemblies or parts as delivered. Drawings and pictures are not to scale and contain symbols for simplification.

2. Warranty

You can find the corresponding specifications in our [General Terms and Conditions](#).

3. Copyright

This manual must be used confidentially. It may be circulated among authorized personnel only. It must not be given to third parties. All documentation is protected by copyright. Distribution or other forms of reproduction of documents, even extracts, exploitation or notification of the contents hereof is not permitted, where not otherwise specified. Infringements are liable to prosecution and payment of compensation. We reserve the right to exercise all intellectual property rights.

4. General safety instructions

Disregard or lack of attention to the information and measures in this manual may pose a hazard to people, animals, the environment and tangible assets. Failure to observe the safety regulations and the neglect of other safety measures may lead to the lapse of liability for damages in the event of damage or loss.

Definitions

- **Operator:** A natural person or legal entity who is the owner of the product and uses the aforementioned product, or is nominated to use it, under the terms of a contractual agreement.
- **Principal:** The legally and commercially responsible party in the execution of construction projects. Legally and commercially liable client in the commission of building projects.
- **Responsible person:** The representative appointed to act by the main contractor or operator.
- **Qualified person (QP):** Any person whose professional training, experience and recent professional activity gives them the requisite professional knowledge. This implies that said person has knowledge derived from relevant national and internal safety regulations.

4.1. Warning symbols in this manual



Warning against hazardous electric current.

Disregarding this could put lives at risk, cause fires or trigger accidents, lead to component overload and damage, or prevent functionality.



Warning against the implications of errors and incorrect set-up conditions.

Disregarding this could lead to serious personal injury, to component overload and damage, or prevent functionality.



Caution! Dangerously high temperatures.

Failure to observe this caution may result in burns to the skin.



You are advised to wear eye protection.

Failure to observe this advice may result in eye injury.



Caution about transporting heavy objects.

Failure to observe this caution may endanger the safety of people in the immediate vicinity of the load.

Caution
Heavy load
use fork lift

4.2. Purpose and use of this manual

The following pages list the information, specifications, measures and technical data that allow the relevant personnel to use this product safely and for the intended purpose.

Responsible persons or those engaged by them carrying out the required services must read this manual attentively and understand it.

Such services include:

Storage, transportation, installation, electrical installation, commissioning and re-starting, operation, maintenance, inspection, repair and dismantling.

Where the product is to be used in plants/facilities which do not comply with harmonised European regulations and relevant technical rules and guidelines of professional associations for this field of application, the present document is purely for informative and reference purposes.

As this unit may be subject to unlimited inspection at all times, this manual must be kept in the immediate vicinity of the installed unit, at least within the confines of the operations room.

Installation classification 2 according to the Annex R of 60730-1.

4.3. Qualifications required, assumptions

All personnel must have the relevant qualifications to carry out the required services and be physically and psychologically capable. The area of responsibility, competence and supervision of personnel is the duty of the Operator.

Required service	Professional group example	Relevant qualifications example
Storage, transportation	Logistics, transport, warehousing	Transport and warehousing specialist
Assembly, disassembly, repairs, maintenance. Re-commissioning after adding or changing components. Inspection.	Installation and building services	HVAC specialist.
First commissioning of configured control unit (generic), re-commissioning after power cut, operation (work on the terminal and Flextronic control unit)		People with operations room clearance with knowledge gleaned from this guide.

Electrical installation	Electrical engineering	Specialist in electrical engineering/ installation
Initial and re-inspection of electrical systems		Qualified person (QP) with certification in Electrical Engineering
Inspection before commissioning and re-inspection of pressure equipment	Installation and building services engineering performed in the context of technical inspection.	Qualified Person (QP)

4.4. Staff qualification

Operating instructions are transferred by Flamco representatives or others assigned by them during delivery negotiations or on demand.

Training for the required services, installation, dismantling, commissioning, operation, inspection, maintenance and repair are part of the training / further education for service engineers of the Flamco branch offices or named service contractors.

These training courses cover information on required installation conditions, but not their implementation.

On-site services include transportation, the preparation of an operations room with the requisite foundation engineering to accommodate the system, and the requisite hydraulic and electrical connections, the electrical installation for the power source of the expansion automat and installation of the signal leads for the IT equipment.

4.5. Appropriate use

Sealed water-based heating and cooling systems in which temperature-induced changes in the volume of the system water (the heat transferring agent) can be absorbed and the required operating pressure is governed by a separate expansion automat.

Suitable and equipped for the operation in heat generating systems according to EN 12828, EN 12952, EN 12953. The Principal / Operator will need to consult with a notified body on additional safety measures.

Use in similar systems (e.g. heat transfer systems for process industry or technologically conditioned heat) may require special measures.

4.6. Incoming goods

The items delivered must be compared against the items listed on the shipping note and inspected for conformity. Unpacking, installation and commissioning may be started only once the product has been checked to conform with the intended use as stated in the order process and contract. Exceeding the permissible operating or design parameters may lead to malfunctioning, component damage and personal injury.

If not in line with conformity or if the delivery is incorrect in another way, the product must not be used.

4.7. Transportation, storage, unpacking



The equipment is delivered in packaging units in accordance with the contract specifications or the specifications required for certain modes of transport and climate zones. These units meet at least the requirements set out in the Flamco B.V. packaging directives. In accordance with these directives, expansion vessels must be transported horizontally and Vacuum degassers upright; each packaged on throw-away pallets. If the packaging is suitable for use with hoisting gear, this will be indicated at the designated hoisting points.



Important note: Transport the packed goods as close as possible to the envisaged set-up location and make sure there is a horizontal, solid surface on which the goods can stand.



Note: Take all necessary precautions to ensure that the expansion vessel cannot topple over or wobble once it has been unpacked and removed from the pallet.

The goods may also be warehoused in their packaging. Once it has been removed from its packaging, the equipment must be put in position, observing standard safety procedures. Do not stack the equipment.

Use only permitted lifting gear and safe tools and wear the required personal protective equipment.

4.8. Operations room

Definition: room which meets the applicable European regulations, European and harmonised standards and relevant technical rules and guidelines of the professional associations for this field of application. For the use of the Vacuum degassers as prescribed in this manual these rooms generally contain equipment for thermal generation and distribution, water heating/cooling and top-up, power source and distribution, such as measuring, control engineering, control technology and IT.

Access for unqualified and untrained persons must be restricted or forbidden.

The set-up location of the Vacuum degasser must ensure that operation, service, maintenance, inspection, repair, installation and dismantling can be carried out unhindered and without danger. The floor of the set-up location for the Vacuum degasser must be such that stability is guaranteed and maintained. Bear in mind that the maximum possible forces can be exerted from the net mass including the water volume.

The ambient atmosphere must be free from conductive gases, high concentrations of dust and aggressive vapours. There is the risk of explosion if any combustible gases are present.

Flooded equipment must not be operated. If electrical equipment short circuits, persons or other beings in the water will be electrocuted. Furthermore, there is a danger of malfunction and partial or irreparable damage to individual components due to water saturation and corrosion.

4.9. Noise reduction

Installations should be constructed with noise-reduction measures in mind. Mechanical vibrations of the assembly (Module framework, pipework) in particular can be dampened by using insulation between contact surfaces.

4.10. Emergency - STOP/ Emergency - OFF

To conform with directive 2006/42/EG an EMERGENCY-STOP facility is to be made available during installation. Preferably, use a grounded wall socket for the power supply to the unit. The socket must stay accessible. If the unit is directly connected to the power supply, make sure the power supply line is provided with:

- a high-sensitivity differential switch (30mA) (residual current device RCD)
- a mains isolator switch with a contact gap of at least 3 mm.

When additional security measures with EMERGENCY-OFF devices are required according to the design and operation of the heat generator, these are to be installed on-site.

4.11. Personal protective equipment (PPE)

PPE must be used when carrying out potentially dangerous work and other activities (e.g. welding), in order to prevent or minimise the risk of personal injury if other measures cannot be taken. These must comply with the requirements specified by the main contractor or operator of the operations room or the site in question.

If no requirements are specified, to operate the automat no PPE is required. Minimum requirements are well-fitting clothing and sturdy, closed and skidproof footwear.

Other services require the protective clothing and equipment necessary for the activity in question (e.g. transport and assembly: rugged, close-fitting work clothing, foot protectors [safety shoes with toe caps], head protection [safety helmet], hand protectors [protective gloves]; maintenance, repair and overhaul: rugged, close-fitting work clothing, foot protectors, hand protectors, eye/ face protector [safety goggles]).

4.12. Exceeding permitted pressure/temperature levels

Equipment used in combination with the Vacuum degassers must guarantee that the permitted operating temperature and the permitted medium temperature (heat transfer medium) cannot be exceeded. Excess pressure and temperature may lead to component overload, irreparable damage to components, loss of function and, as a result, to severe personal injury and damage to property. Regular checks/inspections of these safeguards must be carried out. Service logs must be kept.

4.13. System water

Non-flammable types of water without solids or fibrous components that do not present a danger to operational readiness with their constituents and will not damage water-conducting components of the degassing equipment (e.g. pressurised components, pumps and motor position valves) or have undue influence on its working. Components conducting process water are pipelines, hoses to the vessel, device and system connections, and their casings, sensors, pumps and vessels. Operation with improper media can lead to impaired function, damage to components and, as a consequence, to serious personal injury and damage.

The operating medium must meet the requirements of VDI 2035! Desalinated water must have a conductivity between 10 and 100 $\mu\text{s}/\text{cm}$ with a pH value that does not exceed the allowable limits according to VDI 2035 depending on the material used. When using glycol in your system please set the degassing type to MAX.

4.14. Safeguards

The equipment supplied is equipped with the required safety devices. To test their effectiveness or restore the set-up conditions, the equipment must first be taken out of service. Taking the system out of service implies that power should be cut and hydraulic connections blocked, to prevent accidental or unintentional re-connection.

Mechanical hazards:

The fan-wheel casing on the pump protects operators from personal injury from moving parts. Before commissioning, check that it is fit for purpose and fixed in place.

Electrical hazards:

The protection class of the electrically operated components prevents injury to persons through potentially fatal electrocution. The protection class is at least IP42 (4: Protected against access with a wire; 2: Protection against dripping water if the casing is angled up to 15°.)

The control unit cover, the cover of the pump feed, the motor ball valve connection, the threaded cable glands and the valve connector plugs must be inspected for effectiveness prior to commissioning. Check that the ground connections are tight. The installed pressure sensors, the pressure switch and the temperature sensor are operated with protective low voltage.

Electrical equipment inspections, routine inspection

Without prejudice to the considerations of the insurer/Operator, it is recommended that the electrical equipment of the Vacumat Eco G4 be inspected and documented together with the heating/cooling (see also DIN EN 60204-1 2007).

4.15. External forces

Avoid any additional forces (e.g.: forces caused by heat expansion, flow oscillations or dead weights on the flow and return lines). These can lead to damage / leaks in water-bearing pipework, loss of stability of the appliance and furthermore to failure connected with substantial material damage and personal injury.

4.16. Inspection prior to commissioning, maintenance and re-inspection

These checks guarantee operational safety and its continued presence in line with applicable European regulations, European and harmonized standards and pertinent technical rules and guidelines of the professional associations for this field of application. The required inspections must be arranged by the owner or operator; an inspection and maintenance log book for scheduling and traceability of measures taken must be kept.

4.17. Operating insurance inspections

Pressure equipment, vessels (14; 15)					
Category [see Directive 2014/68/EU]	Vessel nominal capacity/nominal pressure	Inspection prior to commissioning [14] inspector	Re-inspection [15(5)]		
			Timeframe, maximum period [a]/inspector		
			External inspection	Internal inspection	Strength inspection
Art. 3, para. 3	5 litres / PN10	Qualified Person (QP)	Maximum period not defined. The maximum interval must be established by the Operator on the basis of information provided by the manufacturer coupled with practical experience and chamber load. The inspection may be carried out by a Qualified person.		

4.18. Electrical equipment inspections, routine inspection

Without prejudice to the considerations of the insurer/Operator, it is recommended that the electrical equipment of the Vacumat be inspected and documented together with the heating/cooling unit no less than every 18 months (see also DIN EN 60204-1 2007).

4.19. Maintenance and repairs

These services may only be carried out when the system is shut down or if the Vacuum degasser is not required. The Vacuum degasser must be taken out of service and guarded against unintentional re-starting until the maintenance work is finished. Note that the safety circuits and data transmissions made whilst shutting down could trigger the safety chain or lead to false information. Existing instructions for the heating or cooling unit as a whole must be observed. To stop hydraulic components, block the relevant sections and drain them using the safe system water drains through the available drain connections, and relieve the pressure.



Caution: The maximum system water temperature in conducting components (vessel, casings, hoses, pipelines, peripheral equipment) may reach 90 °C and, in the case of improper operation, may exceed that. This presents a danger of burns and/or scalding.



The maximum pressure of system water in conducting components may be equal to the maximum pressure of the Vacuum degasser.

Use of eye/face protectors is required if the eyes or face could be injured by flying parts or spraying fluids.

To stop electrical equipment (control unit, pumps, valves, peripheral equipment), cut power to the control unit. The power supply must remain off for the period of the work.

It is forbidden to alter or use non-original components or replacement parts without authorisation. Such acts may result in serious personal injury and endanger operational safety. They will also render any claim for damages against product liability void. It is recommended to contact Flamco Customer Service for carrying out these services.

4.20. Obvious misuse

- Operation at incorrect voltage and/or frequency.
- Use in inappropriate system designs.
- Use of unpermitted installation materials.

4.21. Other hazards

- Overload of construction parts by the presence of unpredictable extreme values.
- Operational continuity at risk in the case of changed, non-permissible ambient conditions.
- Operational continuity at risk in the case of safety-control parts being taken out of service or malfunctioning.

5. Product description

The contents of this manual consist of the specifications for a standard execution. Where appropriate, this includes information on options or other configurations. If optional extras are supplied, further documentation will be supplied in addition to this manual.

For installation instructions and further documentation in various languages, visit www.flamco.aalberts.com. Further product information can be obtained from the respective Flamco branch office.



This equipment is not designed to cope with sudden, substantial, losses of system pressure (e.g. manual draining) or major water losses (e.g. large leaks). The equipment is also not intended to be used for water boosting (potable) applications.

5.1. Operating principle

The Vacumat Eco G4 pressure and temperature-controlled deaerator for liquids in accordance with VDI 2035 degasses extremely accurately and effectively. Due to the greatly increased and continuous degassing capacity, gases are discharged more quickly. In this way, damage to the system is kept to a minimum, unnecessary malfunctions and expensive repairs are avoided and the service life of the system is extended.

The sensors and speed-controlled, energy saving pump play an essential role in this. Because the pressure and temperature of the system water are continuously measured, the Vacumat Eco G4 automatically chooses the most effective vacuum for optimal deaeration. The appliance is designed to remove dissolved gases without boiling the water in the process. This prevents any released water vapour from interfering with the deaeration process. A boiling process also costs a lot in terms of energy. Not boiling is therefore more effective and cleaner. The Vacumat Eco G4 always automatically regulates the desired deaeration level of the system water and only deaerates as and when necessary (energy saving).

Result: An extremely long service life of cooling and heating systems and big savings on energy costs.

<p>1. Creating a vacuum Because the pump extracts more water from the column than can flow in, a vacuum is created towards the boiling point. Gas is released and collects above the water line.</p>	<p>2. Deaeration The pressure in the column is briefly raised by reducing the speed of the pump so that released gases can be vented.</p>	<p>3. Topping up If the system pressure is too low, deaerated water is added until the correct pressure is reached.</p>
<p>The operation of the Vacumat Eco G4 can be precisely matched to the needs of the user. The appliance offers the choice of three states:</p> <p>Min: Can be used on most systems and uses the least energy. The system is deaerated down to 15 ml of gas per litre of system liquid.</p> <p>Med: Deaerates more powerfully, but also uses a little more energy. Deaeration down to 12 ml/l.</p> <p>Max: Is for optimal deaeration but uses the most energy. Deaeration down to at least 8 ml/l (as per VDI 2035 and 4708).</p>		

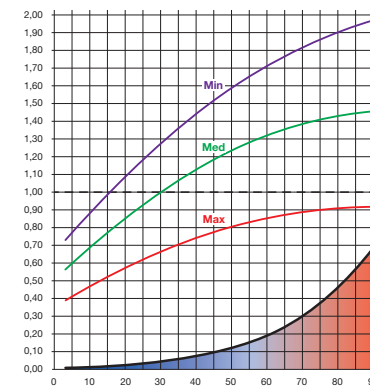

The pressure in the column of the Vacumat Eco G4 follows the boiling line in the graph. The system checks fully automatically whether the system water has been sufficiently deaerated on a short cycle. Depending on the setting level (Min, Med or Max), this deaeration mode follows the respective pressure line. When the gas detector senses that no more gas is released, the system water no longer has to be deaerated. The deaeration cycle stops and a message is shown on the display. The Vacumat Eco G4 continues to regularly check the gas concentration in the system water. If the gas concentration is too high, the Vacumat Eco G4 automatically activates the deaeration program.

5.2. System diagram

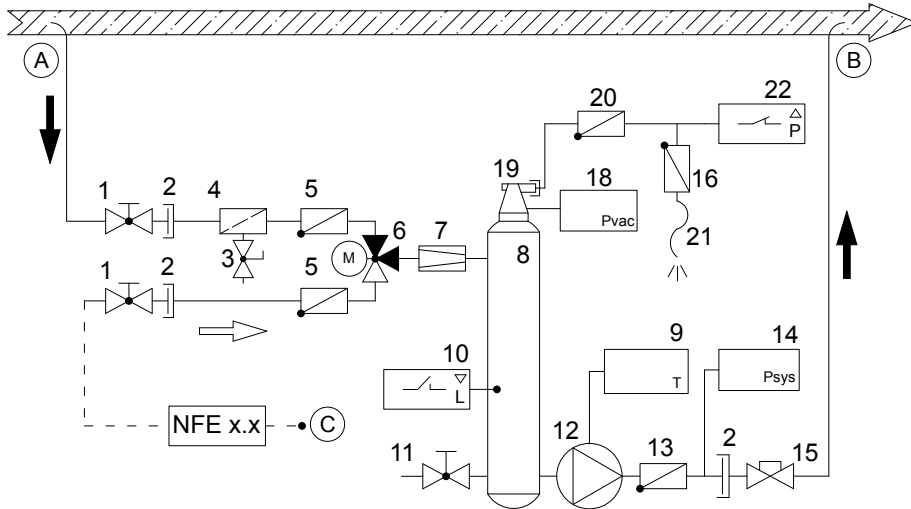

A From system: Supply to Vacumat Eco G4 with gas-rich medium
 B to system: Return from Vacumat Eco G4 to system circulation with degassed medium
 C Top-up connection point (NFE x.2 - variable, optional wiring)

1	Ball valve	12	Pump with frequency converter
2	Flat sealing threaded connection on non-return valve	13	Check valve
3	Filling and drain valve	14	System pressure sensor
4	Dirt trap (0.5 mm)	15	outlet valve
5	Check valve	16	Special check valve
6	3-way switch motor ball valve	17	Sensor insulation
7	Volume flow limiter	18	Pressure Sensor - degassing vessel
8	Degassing vessel	19	Automatic de-aerator
9	Temperature contact sensor	20	Aeration preventer (check valve)
10	Filling level limit switch	21	Vent line
11	Drain valve (with cap)	22	Pressure switch

5.3. Component parts, vessels and connection assembly

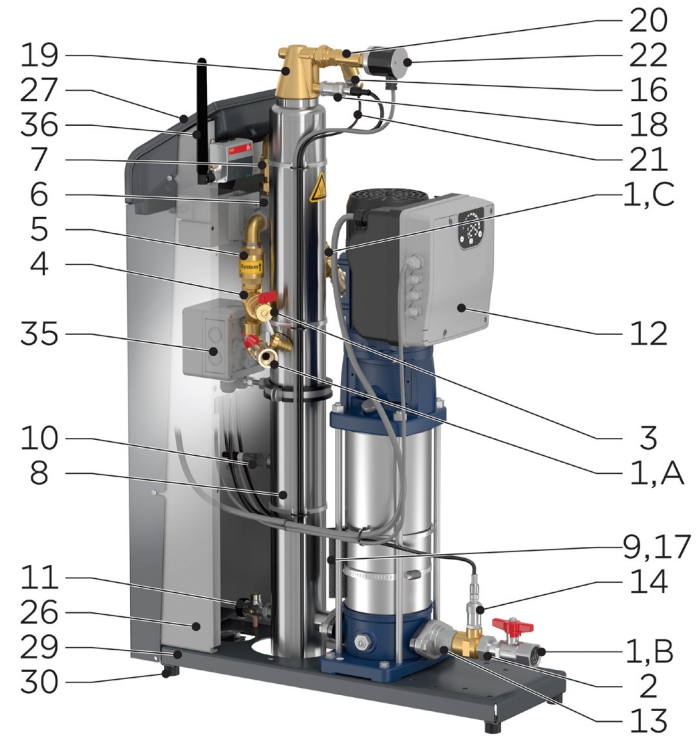

26	Ground connection for applying the external equipotential bonding (protective earth conductor)
27	Flextronic Control unit
29	2x mounting hole (to ensure stability against tipping)
30	Rubber buffers (for sound insulation; insulation against structure-borne sound propagation)
35	Powerbox

5.4. Mode of operation

The Vacumat Eco G4 works as an active degassing device with automatic top-up.

Degassing is performed by removing system medium from the system circulation through a bypass. This is conveyed through the system connection **(A)** and the following volume flow limiter **(7)** into the degassing vessel **(8)**. During pump operation, the degassing vessel **(8)** is placed under a defined negative pressure. The ability of air to dissolve in the system medium is heavily reduced by the lowered pressure, causing bubbles to form, accumulate and expand and this air to rise.

The process is facilitated by the rotating air separator principle where the air is separated and unified by the tangential inflow, intensified towards the middle of the vessel (in the air head of the degassing vessel). This optimises degassing.

All free gases and a proportion of dissolved gases are removed from the system in an energy-saving manner which is considered non-critical in terms of:

- Corrosion.
- Heat transfer to heating surfaces.
- Flow behaviour in the system.

This works, among other reasons, because the frequency-controlled pump with adjusted speed gently regulates the vacuum to be built up to an energetically meaningful level (temperature-controlled), thus avoiding pressure surges.

After reducing the pump speed, the vessel is placed under system pressure by subsequent medium flow, resulting in the discharge of the air collected above water level via the de-aerator unit **(16, 19-22)**.

The Vacumat Eco G4 performs check degassing cyclically in order to automatically pause the degassing when the preset gas content level is reached. This is checked and decided at the de-aerator unit.

Pressure switch **(22)** detects whether air still exists at charge level, which leads to preset vacuum control at the degassing system by (Reduced degassing = MIN, Normal degassing [default] = MED, and Strong degassing = MAX).

When using glycol in your system please set the degassing type to MAX

The quantity of medium supplied to the vessel is returned to the circulation line system connection **(B)** return via a bypass line while the pump is running. Cyclical degassing takes place in "Fully automatic" mode. In this mode, the pump running time (vacuum build-up) alternates with the ejection of the separated air (reduced pump speed).

Although the Vacumat Eco G4 works very quietly, fully automatic degassing operation mode can be interrupted by freely programmable breaks (e.g., at night). It is also possible to switch off degassing. The system is then in standby mode. Topping-up can

still be done in this mode as needed.

5.5. Top-up

Both pressure-controlled and level-controlled topping-up can be performed.

Topping-up occurs when the motor ball valve **(6)** switches; medium then passes into the Vacumat Eco G4 through the top-up opening **(C)** and is fed to the system by the pump.

Topping-up interrupts breaks and standby operating mode, or follows completed cycles of normal degassing or check degassing. If the top-up requirement is active, it is primary to all other processes because the pressure must be maintained above all else.

5.6. Pressure-controlled top-up

Equivalent to factory setting to top-up pressure holding systems with (passive) diaphragm pressure expansion vessels. The top-up pressure setpoint can be edited in the pressure menu.

5.7. Level-controlled or externally-controlled top-up (for active pressure maintenance)

The operator has the option to use the level-controlled top-up for pressure maintenance using an automatic pressure holding device.

(See terminal diagram / electrical connection) Topping-up occurs here for as long as the external top-up request is present and Vacumat Eco G4 volume or time-monitoring allows it.

5.8. Top-up OFF

Top-up can also be disabled via software.

5.9. Operating mode - fully automatic

Once the system has been fully set up (Start menu completed) and commissioned, and the control unit has been switched on, a delay first occurs; then the temperature in the machine is initially adjusted for a preset period before it is measured. Based on the temperature and the preset check degassing mode, the process in the vessel is regulated so that, after a certain time, it is possible to determine at the pressure switch whether undissolved air still exists in the medium at the level predefined by the degassing mode.

If this is not the case, no air is discharged in check degassing and degassing is interrupted; then, after readjusting the temperature, the gas load is tested again and the process is repeated.

However, if air is discharged from the vessel in the check degassing discharge phase, check degassing is followed by normal degassing; a lower negative pressure is built up than in check degassing and the medium is undersaturated with respect to the existing gas charges. This is repeated cyclically until either check degassing is pending, or the system switches to a degassing wait because no air is discharged at the end of the discharge phase during normal degassing. The system then continues with the temperature adjustments and check degassing after a specified interval time.

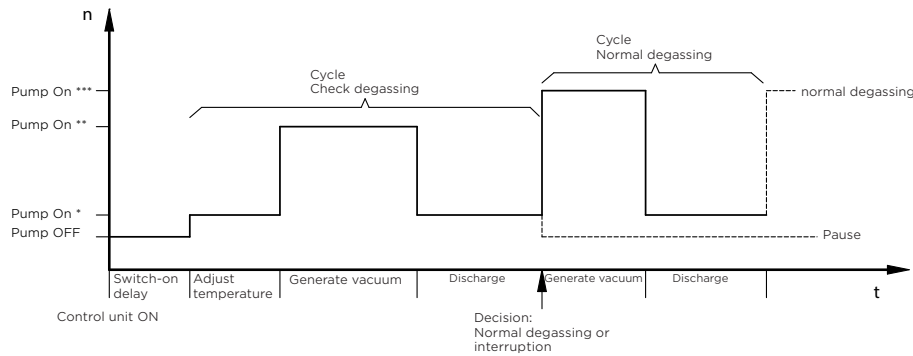

- * Pump runs at a low speed level in order to achieve discharge pressure in the vessel.
- ** Pump runs at a higher speed level in order to build up the target vacuum in the vessel.
- *** Pump runs at a high speed in order to build up a stronger vacuum in the vessel and degas effectively.

5.10. Standby operating mode

Topping-up only occurs in this mode during «virtually permanent pauses» in normal degassing, and thus interrupts the pauses. Check degassing is not performed. In addition, the standby setting can also be induced by bridging contact P25 (takes priority over the software setting).

This can be used to, for example, switch off degassing remotely or also to interrupt degassing when the circulation pumps are switched off to prevent inefficient degassing. It is not necessary to wait until the Vacumat Eco G4 detects this problem (with a delay) after check degassing or because no gas is discharged during normal degassing.

5.11. Break times / exclusion times with blocking intervals

Break times for degassing can be defined so that a time-limited standby mode is implemented automatically.

5.12. Vacuum test

Requires the supply connection to be shut off when the vessel is full (coming from the system return). When doing so, the pump generates a vacuum after a couple of seconds; the vacuum must remain stable for a specified period of time in order to verify the pump's performance and ensure the vessel is leak-tight. This test typically needs to be performed prior to commissioning and after maintenance.

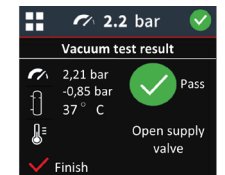
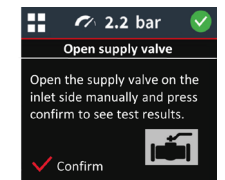
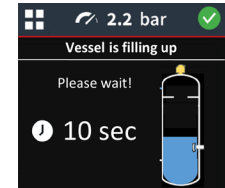

5.13. Manual mode

NOTE: Manual mode disables all safety check's therefore this functionality should be used by QP only. The needed safety precautions should be evaluated before the use of this mode and could differ per situation.

5.14. Connectivity options

Connectivity options	Designated use
Ethernet port	To connect Vacumat Eco G4 to a Building Management System (BMS) via modbus or bacnet.
Standard USB (aka USB-A)	For saving the offline log and the configuration parameters. The second option for this port is to update the firmware of the controller (to download a new control SW)
CAN	This pair of the ports is dedicated for the networking of multiple Flamcomats
RS-485	The primary designation is to connect Flamcomat to Internet (via Gateway and HFC protocol). Alternatively - BMS via Modbus Alternatively - BMS via bacnet (only one out of three options at the same time)
Wireless	To connect a smartphone application

See also Appendix 3: Flamconnect & remote portal

[Link Flextronic Connectivity Guide](#)



QR-code Flextronic Connectivity guide

5.15. Markings

(with examples and placeholders for variable information)

Marking	Location
Type plate	Right side of white console
Control unit type plate	Front side of control unit
Electrical safety sign	Powerbox
Service numbers	Right side of white console
Hot surface	Stainless steel vessel/bottle

5.16. Control unit

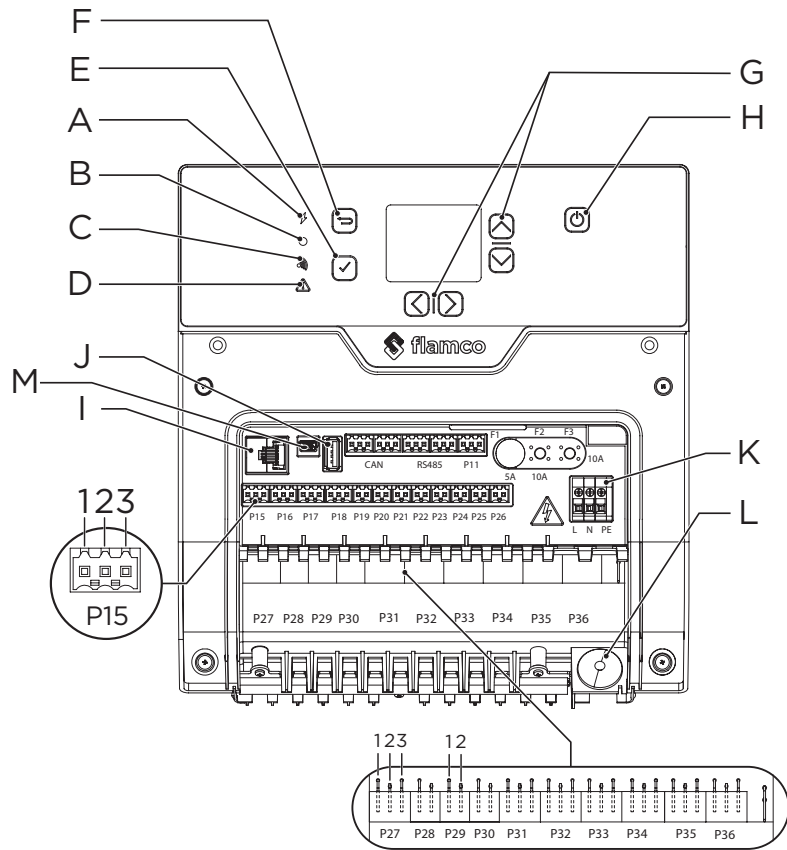

Identification	Description	Pinout
A	Power indicator (orange=power)	
B	Status indicator (green=ok amount running)	
C	Wireless indicator (blue light = active)	
D	Error/alarm (red=alarm/error active)	
E	Confirm button	
F	Return button	
G	Navigation buttons	

H	Screen on/off hold 5 sec for powerdown	
I	RJ45 connector used for Modbus/Bacnet over TCP/IP	
J	USB-A software update	
M	Micro-USB	
CAN	CAN connection	1. CAN Hi 2. CAN Lo 3. GND
RS485	Modbus/BacNet/HFC over RS485	1. B+ 2. B- 3. GND
F1	Fuse 1 (P31&P32) 5x20 5A	
F2	Fuse 2 (P33&P35) 5x20 TT10A	
F3	Fuse 3 (P34&P36) 5x20 TT10A	
K	Mains power connector	1. L 2. N 3. PE
L	Main grommet	
P11	RPM Controller	1. 0-10V 3. GND
P15	System pressure	1. +VDC 2. -VDC
P16	Vacuum pressure	1. +VDC 2. -VDC
P17	Temperature sensor	1. +VDC 2. -VDC
Identification	Description	Pinout
P18	Level Switch	1. 12VDC 2. signal 3. GND
P19	Pulse water meter (Top-up)	1. NO
P20	Not used	
P21	Top-up in low voltage	1. NO
P22	Gas sensor	1. NO
P23	Not used	

P24	FC fault	1. NO
P25	Standby input	1. NO
P26	Pressure analogue out	1. 0-10V
		2. GND
P27	Fault contact, Pot free 1	1. N C
		2. COM
		3. NO
P28	Fault contact, Programmable fault output Pot free 2	1. COM
		2. NO
P29	Fault contact, Programmable fault output Pot free 3	1. COM
		2. NO
P30	Top-up in 230V	
P31	Not used	
P32	Not used	
P33	Motor valve	2. L
		3. N
P34	Not used	
P35	Pump	1. PE
		2. L
		3. N
P36	Not used	

6. Assembly

6.1. Installing, levelling, bolting - Ensure stability!



Set up the unit on a flat and stable (concrete) surface near the well in the operating / boiler room.

Ensure that a floor drain is available for the unit!

Use both frame holes on the base plate (Ø12) to secure the Vacumat Eco G4 against tipping. Use sufficiently long (stainless) steel screws Ø10 (with plugs and possibly plastic washers) for this in order to anchor them in the ground in such a way that tipping can be prevented, but so that the screw does not transmit structure-borne noise. (Do not tighten the screw too tightly.) Note the required minimum distances to walls, maintenance areas and assembly areas (see 9.3 Minimum distances: clearance for service and repair)

6.2. Connecting the pipework

Note: Only working temperatures of between 3 and 90 °C are permissible. Bear this in mind when selecting the place of installation.

Make sure that this connection is made solely with the heat generator and that there are no external hydraulic pressure influences present at the point of entrainment (e.g. hydraulic balancers, distributors).

Pipeline diameters must be at least size DN32 (1¼") on the unit's pressure ports.

If the pipework length is more than 10 metres from the pressure ports to the return pipe, the connection pipes must be at least DN40 (1½"). The inlet connections from the system and topping up must be at least DN20 (¾"). At least DN32 (1¼") must be used for pipelines longer than 10 m. The branch pipe connection lengths to the system must not exceed 20 m. For every 90° bend, one metre of the maximum permitted pipe length must be deducted.

Use sealants and feed lines appropriate to the installation; however, please observe at least the maximum permitted volumetric flow, pressure and temperature values for the pipework in question. (See appendix 1 for diagram.)

Make sure that all connections to the unit are installed so that they are without tension at the joints!

Reinforced hoses must not be subjected to tension, twisting or kinking, etc. If a reinforced hose is used on the inlet to the unit it must be designed to be vacuum-tight!

6.3. Connecting the electrical supply



The power supply connection must be created by the customer between the mains supply and the Powerbox.
 The mains supply, earthing system and cable protection must be provided in compliance with the requirements of the responsible power supply company (PSC) and the applicable standards. The required information can be found on the type plate of the control unit and the terminal plan.
 The mains connection to be provided via a suitable CEE plug / socket combination with load-switching ability or other permissible main switch. This electrical installation work must be performed by qualified electrically skilled personnel.
 Note: install equipotential bonding between the earth connection and equipotential bonding conductor. The minimum diameter, quality and type of the power cables must comply with the rules and regulations applicable at the installation location for this application. Electrical power cables should be guided along cable gutters at all times.
 The finished system allows the user to program the configuration and system-dependent parameters into the control unit. Also the Gateway will be powered by the Powerbox.

Unfasten the four screws of the Powerbox to open the cover.

Supply the Powerbox with a mains power cable through the included cable gland and connect live to L1, neutral to N and green/yellow to PE.

Close the cover and fasten the four screws of the Powerbox again.

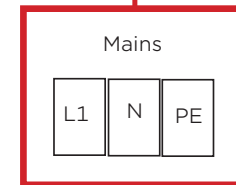
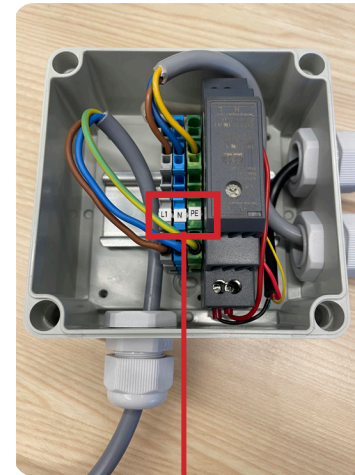

For more detailed instructions regarding the top-up function check additional instructions at www.flamco.aalberts-hfc.com.

7. Commissioning

7.1. Initial commissioning

- Document the commissioning procedure (actions and settings)
- Check that the installation and other actions prior to use have been carried out in full (e.g. power supply available and connected, functioning or active fuses and protective conductor connections, equipment is free from leaks, the product is levelled and has a stable setup).

Commissioning is preferably done via Flamconnect App

- Connect the mains power, and accessory connections. Following the requirements in chapter 6.3 'Electrical installation'.
- For the Vacumat Eco G4 to function correctly, it is essential that the temperature sensor (Pos. 9 in the system diagram) has a reliable, fixed contact with the pump body through the tensioning strap that attaches it to the pump body. It is also very important that the temperature contact sensor is sufficiently shielded against ambient temperatures with the sensor insulation (Pos 17). This must always be checked during commissioning, system inspection, servicing or maintenance!
- After the inlet valves and the outlet valve on the unit have been opened, the vessel fills with system medium. The air in the vessel is discharged via the de-aerator unit. Check the system impermeability. Once this is done, the control unit can be switched on. The Flamco logo and the control unit software version are displayed.
- Run the commissioning procedure and follow the steps on the Flextronic controller to set up the Vacumat:
 1. Language selection
 2. Activate Bluetooth
 3. Time/ Date settings
 4. Confirm manual is read
 5. Select accessories
 6. Set input parameters
 7. Confirm commissioning requirements
 8. Confirm Summary
- After scrolling down and confirming the "Summary menu", the system starts fully automatic operation.
- It is strongly recommended to perform the vacuum test after commissioning and maintenance. [See chapter 5.12 "Vacuum test"](#).
- The completion of all the tasks to be carried out, the review of technical data,

recommendations and explanations in this manual lead to the degasser being ready for operation.



For the Vacumat Eco G4 to function correctly, it is essential that the temperature sensor (Pos. 9 in the system diagram) has a reliable, fixed contact with the pump body through the tensioning strap that attaches it to the pump body. It is also very important that the temperature contact sensor is sufficiently shielded against ambient temperatures with the sensor insulation (Pos 17). This must always be checked during commissioning, system inspection, servicing or maintenance!

7.2. Settings / control actions

Once worked through the commissioning steps and the system has started up, the system its status can be precisely monitored using various operational indicators in the main screens. Including a statistical analysis of the system values, see table below. The basic menu structure can be found in Appendix 3: 'Menu structure' of this document.

It is possible to change the existing settings via Settings menu . Pressure settings,

accessory settings and maintenance settings can only be adjusted after Log in  Settings.

These settings should only be changed by a QP.

Main menu screens

1	System pressure	5	Vessel pressure
2	Countdown until next degassing cycle (hh:mm:ss).	6	Total litre count
3	Date of next maintenance	7	Top-up count over the last 28 days.
4	Degassing type MIN, MED, MAX When using glycol in your system please set the degassing type to MAX	8	Degassing amount indication bar. Shows how long the degassing cycle has been on in a time span of 4 hours.
		9	Press up button to start vacuum test

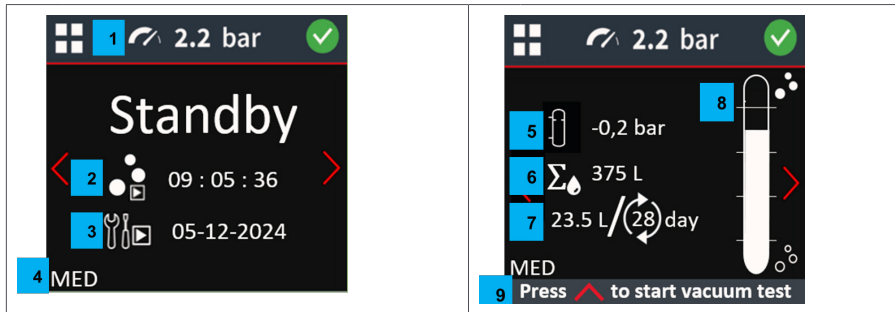

7.3. Recommissioning

Recommissioning (e.g., after extended periods of inactivity / shutdown and maintenance) assumes that the system is free from leaks and correctly connected electrically. After extended downtimes it is advisable to perform maintenance before recommissioning.



For the Vacumat Eco G4 to function correctly, it is essential that the temperature sensor (Pos. 9 in the system diagram) has a reliable, fixed contact with the pump body through the tensioning strap that attaches it to the pump body. It is also very important that the temperature contact sensor is sufficiently shielded against ambient temperatures with the sensor insulation (Pos 17). This must always be checked during commissioning, system inspection, servicing or maintenance!

8. Maintenance

The components of the Vacumat Eco G4 are largely maintenance-free. Nevertheless, it is recommended to perform an annual visual check of the system (including for leaks). In addition, the dirt trap / Flamco XStream Clean to be provided by the customer in the inflow line must be cleaned at least once a year, even if automatic detection does not require this. Cleaning may also be done at more frequent intervals (depending on how dirty the system water is).

Should a visual check of the system necessitate further maintenance, this may also only be done by qualified personnel.

The temperature contact sensor must be visually inspected (Check assembly) at least during maintenance! (already described in Commissioning)

- It is strongly recommended to perform the vacuum test after commissioning and maintenance. See [chapter 5.12 "Vacuum test"](#).

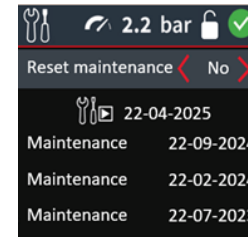

Via the menu items; Service info **i** Maintenance **??**, the maintenance overview can be used to check the next service date. The QP can set and change the next maintenance date by going into the maintenance menu via; Log in **i** Service info **i** Maintenance **??**.

If the system clock is correctly set, the QP will be informed about reaching the date via a Warning message, "Maintenance # is due", on the controller and the Flamconnect app (if connected).



Maintenance warnings pops-up when date is due. Warning gets stored in the Current errors/warnings list and Error logbook.

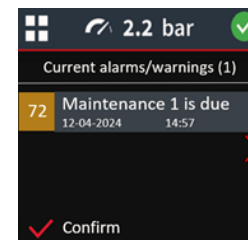

Acknowledging the "maintenance 1 is due" warning in the Current errors/warnings list is equal to resetting the maintenance 1 due date.

Acknowledging the "maintenance # is due" warning should only be confirmed by a QP. The control unit then determines the next service date by itself.

365 Days for maintenance are provided after commissioning. The Vacumat Eco G4 continues to work while the maintenance warning is active.



For the Vacumat Eco G4 to function correctly, it is essential that the temperature sensor (Pos. 9 in the system diagram) has a reliable, fixed contact with the pump body through the tensioning strap that attaches it to the pump body. It is also very important that the temperature contact sensor is sufficiently shielded against ambient temperatures with the sensor insulation (Pos 17). This must always be checked during commissioning, system inspection, servicing or maintenance!

8.1. Malfunction messages

If any errors other than those described occur and they cause permanent problems (not self-acknowledging), please contact your local service engineer to solve the problem!

#	GUI	Action	Effect when alarm is active
64	System pressure loww	System pressure is outside working pressure range. Check for leaks, isolation valves and low pressure setpoint.	NO effect
65	System pressure high	System pressure is outside working pressure range. Check isolation valves, expansion vessel size and pre-charge and high pressure setpoint. Top-up/degassing is disabled until resolved.	NO effect
66	No Top-up flow	Litres counter does not detect flow after top-up request. Check if isolation valves are closed, check three-way valve malfunction and check mains water supply pressure. Top-up/degassing is disabled until resolved.	Degassing disabled Internal top-up disabled External top-up disabled
67	Time between Top-up cycles too short	Large amount of water was lost, unit is undersized for the system or flood limit time is too short. Top-up is disabled until resolved.	Degassing disabled Internal top-up disabled External top-up disabled
68	Top-up cycle quantity limit exceeded	Large amount of water was lost, unit is undersized for the system or flood limit time is too short. Top-up is disabled until resolved. Maximum number of cycles within time window exceeded.	Degassing disabled Internal top-up disabled External top-up disabled

69	Fill Error	Filling without request (litres counter sends signal without filling). Check 3-way valve for errors. Top-up is disabled until resolved.	Degassing disabled Internal top-up disabled External top-up disabled
70	Maximum top-up time per cycle exceeded	Large amount of water was lost, unit is undersized for the system or flood limit time is too short. Top-up is disabled until resolved.	Degassing disabled Internal top-up disabled External top-up disabled
71	Runtime Protection	Maximum time of top-up cycle exceeded. Large amount of water was lost, unit is undersized for the system or flood limit time is too short. Top-up is disabled until resolved.	Degassing disabled Internal top-up disabled External top-up disabled
72	Maintenance 1 is due	A periodic maintenance is due. Contact your local service engineer.	NO effect
73	Pump protection active	Pump protection signal is activated. Check pump for short cuts or overheating signals. Top-up/degassing is disabled until resolved.	Degassing disabled Internal top-up disabled External top-up disabled
74	Manual Mode Active	Manual Mode activated. Automatic mode disabled.	Degassing disabled Internal top-up disabled External top-up disabled
75	Device restarted	Device lost power or has recently been restarted. Top-up/degassing were disabled during this time.	NO effect
77	Water filter full	Clean out the water filter according to the manual.	NO effect
78	External Standby Request	Input P25 is activated. Vacumat in degassing standby mode. System degassing is disabled until resolved. Top-up is still enabled.	Degassing disabled
79	Internal Standby	Vacumat degassing standby mode activated. System degassing is disabled until disabled in degassing menu. Top-up is still enabled.	Degassing disabled
80	Too deep Vacuum in vessel	Too deep vacuum reached in vessel. Boiling risk. Check if isolation valves are open. Check level sensor for defect.	NO effect

81	Insufficient Vacuum in vessel	Insufficient Vacuum pressure for successful degassing. Check for leaks, defective check valves or a defective air vent.	NO effect
82	Gas sensor not connected	Gas sensor is incorrectly wired or defective. Check wiring plug P22 and wires on gas sensor side. Top-up/degassing is disabled until resolved.	Degassing disabled Internal top-up disabled External top-up disabled
83			

#	GUI	Action	Effect when alarm is active
0	System pressure critically low	System pressure is below critical pressure limit. Check for leaks, low pressure setpoint and open isolation valves.	Degassing disabled Internal top-up disabled External top-up disabled
1	Low pressure lockout	Zero pressure in the system. Open isolation valves, check for leaks and fill system. Top-up degassing is disabled until resolved.	Degassing disabled Internal top-up disabled External top-up disabled
2	System pressure sensor no signal	The system pressure sensor is not connected or defective. Check wiring from P15 to the sensor. Top-up/degassing is disabled until resolved.	Degassing disabled Internal top-up disabled External top-up disabled
3	System pressure sensor short circuit	The system pressure sensor is defective or incorrectly wired. Check wiring from P15 to the sensor. Top-up/degassing is disabled until resolved.	Degassing disabled Internal top-up disabled External top-up disabled
4	System pressure critically high	System pressure is above critical pressure limit. Open isolation valves, check expansion vessel size and pre-charge and high pressure setpoint. Top-up/degassing is disabled until resolved.	Degassing disabled Internal top-up disabled External top-up disabled
5	Vacuum pressure sensor no signal	The vacuum pressure sensor is not connected or defective. Check wiring from P16 to the sensor. Top-up/degassing is disabled until resolved.	Degassing disabled Internal top-up disabled External top-up disabled

6	Vacuum pressure sensor short circuit	The vacuum pressure sensor is defective or incorrectly wired. Check wiring from P16 to the sensor. Top-up/degassing is disabled until resolved.	Degassing disabled Internal top-up disabled External top-up disabled
7	Temperature sensor no signal	The temperature sensor is not connected or defective. Check wiring from P17 to the sensor. Top-up/degassing is disabled until resolved.	Degassing disabled Internal top-up disabled External top-up disabled
8	Temperature sensor short circuit	The temperature sensor is defective or incorrectly wired. Check wiring from P17 to the sensor. Top-up/degassing is disabled until resolved.	Degassing disabled Internal top-up disabled External top-up disabled
9	Pump failure (max. current exceeded)	The pump is defective or incorrectly wired. Check wiring from P35 to the pump. Top-up/degassing is disabled until resolved.	Degassing disabled Internal top-up disabled External top-up disabled
10	Pump failure (no current)	The pump is not connected or defective. Check wiring from P35 to the pump. Top-up/degassing is disabled until resolved.	Degassing disabled Internal top-up disabled External top-up disabled
11	Vacuum error	3 times insufficient vacuum. Check for leaks in the vessel, check pipe connection size requirements are met, check if flow limiter is installed. Top-up/degassing is disabled until resolved.	Degassing disabled Internal top-up disabled External top-up disabled
12	Pump dry run protection activated	Continuous low medium level in vessel. Check for leaks in the vessel, check pipe connection size requirements are met, check inlet pressure. Top-up/degassing is disabled until resolved.	Degassing disabled Internal top-up disabled External top-up disabled
13	Temperature of the medium too low	The temperature of the medium at the automat inlet is lower than 3°C. Top-up/degassing is disabled until resolved.	Degassing disabled Internal top-up disabled External top-up disabled
14	Temperature of the medium too high	The temperature of the medium at the automat inlet is higher than 90°C. Use an intermediate vessel in your system. Top-up/degassing is disabled until resolved.	Degassing disabled Internal top-up disabled External top-up disabled

9. Appendix 1: Technical data, general specifications

9.1. Ambient conditions

Storage space/Operating area		
Room:	Protected against:	Ambient conditions:
Locked; frost-free; dry.	Solar radiation; thermal radiation; vibration.	60 ... 70% relative humidity, non-condensing; Maximum temperature 45°C; free of electrically conductive gases, explosive gas mixtures, aggressive atmosphere. Note! Higher temperatures in the operating area can result in drive overload.

9.2. Installation examples

Integration in a heating system

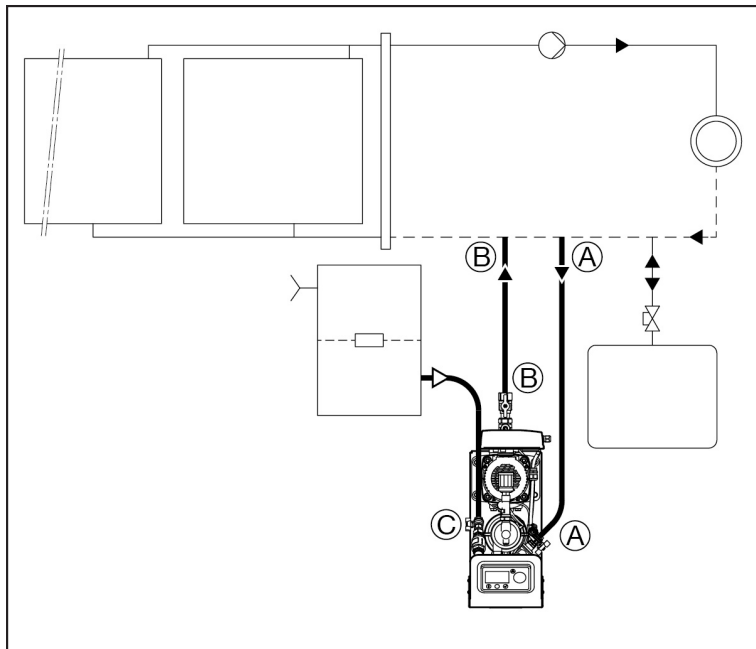

Example of a unit / pipeline integration

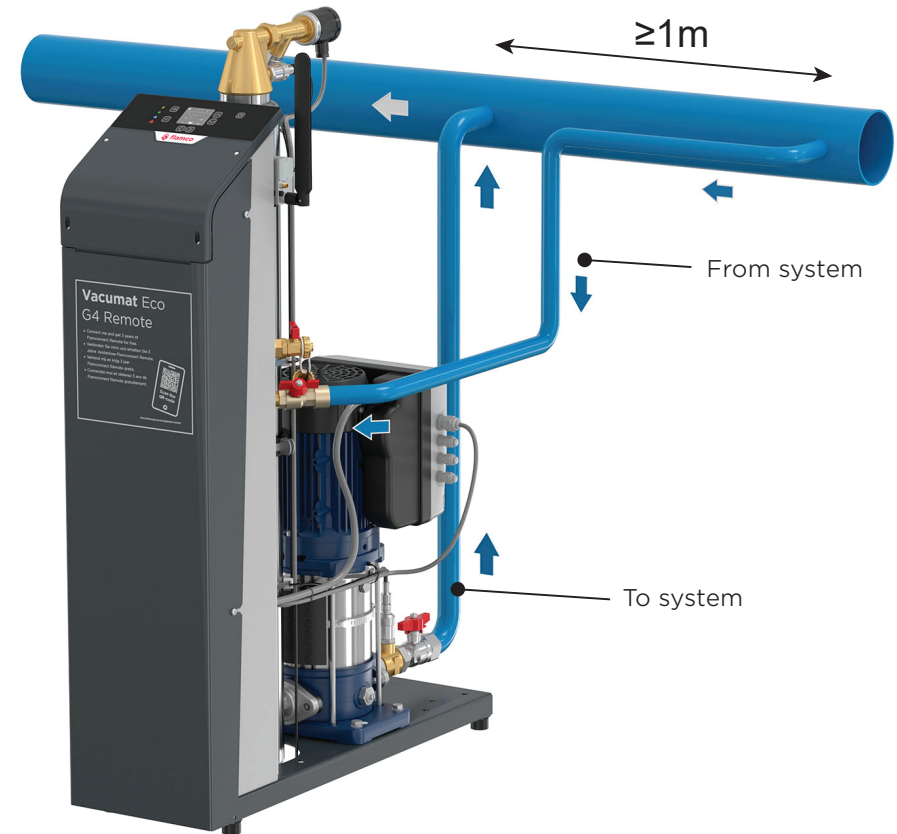

- Install connections at the side of the pipe – do not install at the bottom of the pipe, this will contaminate the Vacumat!
- Regard the pipe length in correlation with the diameter and the number of bends.

From System:

< 10m ≥ DN20 (¾")
 > 10m ≥ DN32 (1¼")
 max. length 20m
 1 x 90° > max. length = 19m
 3 x 90° > max. length = 17m

To System:

< 10m ≥ DN32 (1¼")
 > 10m ≥ DN40 (1½")

- Regard the minimal required distance between the system connections: ≥ 1m

9.3. Minimum distances: clearance for service and repair

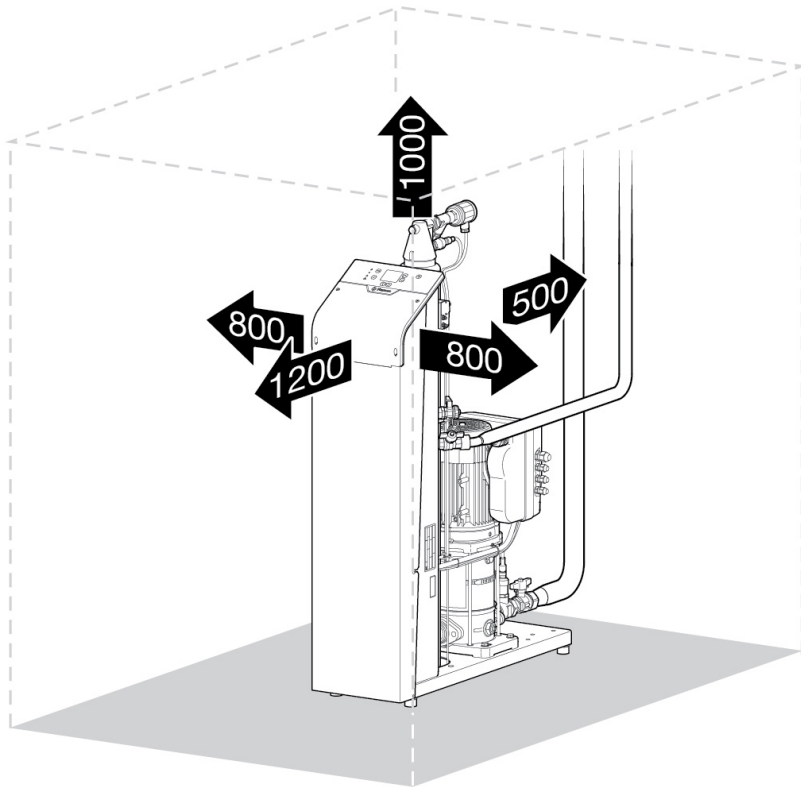

10. Appendix 2: technical data and specifications

Vacumat Eco G4	300	600	900
Fully automatic stationary degassing and top-up machines for heating and cooling water systems.			
Hydraulic connection data:			
Medium	Water-based heat carrier as per VDI 2035 Max. glycol ≤ 50% and no distilled water. When using glycol in your system please set the degassing type to MAX.		
Nominal pressure	PN 10		
Working pressure range	0.6 - 2.7 bar	0.8 - 5.4 bar	0.8 - 8.7 bar
	High pressure alarm @ 0.9 * safety valve setting (set during commissioning)		
Permissible operating temperature range (medium)	3 - 90 °C		
Standard for the system	DIN EN 12828 or cooling water system		
Top-up flow pressure	0.2* - 9.0 bar		
Adapted medium throughput (system medium)	up to 1000 litres/h		
Top-up volume	up to 1000 litres/h		
Permissible system flow temperature	3 - 120 °C		
Hydraulic connections	Supply from system; Rp $\frac{3}{4}$ " to the ball valve Top-up connection; Rp $\frac{3}{4}$ " to the ball valve Return to system; Rp1" downstream of ball valve		
Pump venting (system filled)	Automatic		
Electrical specifications:			
Operating voltage	1x 230 V (EN 50160)		
Mains frequency	50 Hz (EN 50160) / 60 Hz ±1%		
Rated power	0.55 kW	0.75 kW	0.75 kW
Nominal current	2.23 A	4.09 A	4.09 A
External fuse	16 A (C)		
FI external	Universal current sensitive RCD 30 mA, inverter-capable		
Degree of protection	IP42		
General data:			
Ambient conditions:	3 - 45 °C		
Maximum noise emission (< 30% glycol)	52 dB(A)	55 dB(A)	-55 dB(A)
Adjustable degassing level MAX	8 ml/l of gas		
Adjustable degassing level MED	12 ml/l of gas		

Adjustable degassing level MIN	15 ml/l of gas		
Vacumat Eco G4	300	600	900
Dimensions and weights:			
Width x depth x height; approx.	260 mm x 690 mm x 1030 mm		
Net weight	37.5 kg	39.8 kg	46 kg
Type of packaging	Wooden pallet with cardboard wrapping, IPPC standard		
Packaging dimensions			
Width x depth x height; approx.	600 mm x 800 mm x 1315 mm		
Gross weight approx.	48.7 kg	51.0 kg	57.2 kg
* With top-up from a system separating vessel; otherwise 1.3 bar.			

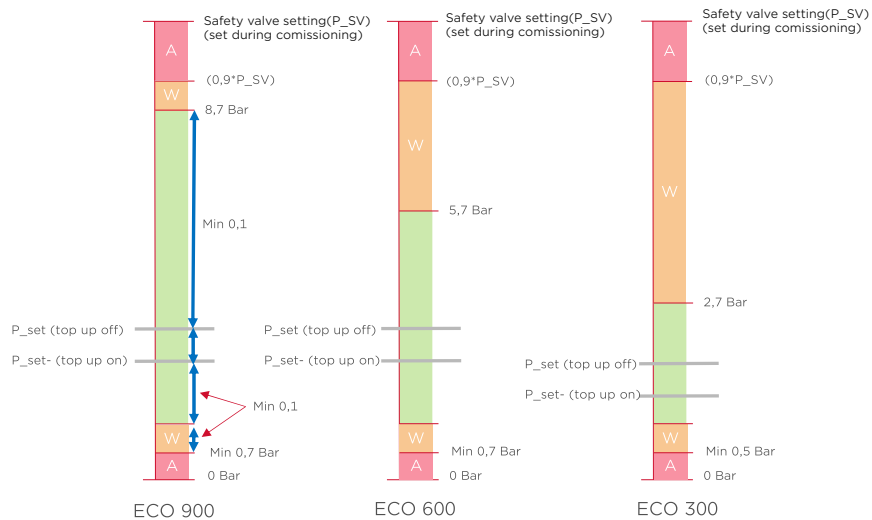

11. Appendix 3: Flamconnect & remote portal

The Vacumat Eco G4 comes with a 3-year Flamconnect Remote. Flamconnect Remote provides the option to read and control the Vacumat Eco G4 via the Flamconnect Remote Portal. More information can be found at <https://flamco.aalberts-hfc.com/nl/page/services/flamconnect-remote>.

A Gateway is used to make communication possible. This gateway connects to the Vacumat Eco G4 via RS485. The gateway is connected to the Flamconnect Remote Portal via a GSM network. After you have completed the registration of the gateway, you will have access to the Flamconnect Remote Portal.

Requirements for proper operation:

- There must be good GSM coverage where the gateway is located. If this is not the case, item 90009 can be ordered. This is an antenna with cable, the cable can be connected to the gateway, the antenna can be placed at a location with a good GSM network.
- Check whether the antenna is properly connected to the gateway.
- Communication from the Vacumat Eco G4 via RS485 port must be set to “gateway”.
- The serial number required during registration can be found on the back of the gateway.



Security

What safety measures are there?

We take your data very seriously, so we have a host of security measures in place to ensure your data stays safe. Below is a small subset of these measures to give an idea of their scope:

- The portal team has a daily focus on security, with peer reviews, static code checking, automated testing, etc.
- Security is designed into the multi-level portal. Developers, for example, must explicitly code for situations where they need data that would normally not be accessible to the logged in user, because otherwise that data is simply «invisible.»
- All access is password protected. All users are authorized using roles and permissions using standard Microsoft certified solutions.
- IoT connections are encrypted with TLS and access keys or certificates (depending on customer requirements).
- Our portal has measures to actively protect against CORS, XSS, Content-type sniffing, Framing, etc.
- Actions on sensitive data (e.g. device data / user accounts) are logged in an audit trail.
- Deployments are fully automated to avoid configuration errors that could lead to security breaches.
- Internal and external security is actively screened through pen tests and security audits.
- In addition to our built-in security measures, we can also configure additional measures, for example Cloudflare to protect against DDOS attacks or Azure API Management to throttle API clients that make too many requests.
- Last but not least, we use Microsoft Azure and all it has to offer in terms of security, data encrypted at rest, keyvaults, no practical physical access and of course their team of world class security experts!

By using Flamconnect Remote you agree to the Contract and Terms of Use”.

12. Appendix 4: Optional accessories and their integration

Optional accessories and their integration Otherwise, the unit is fully set up.

12.1. System separation by top-up unit (NFE)

Top-up medium must be free of particles (greater than 0.5 mm) and long-fibered components.

If the system still needs to be separated (from the potable water network), it is possible to use NFE 1.1 and NFE1.2. See System layout - system diagram.

The inlet flow pressure to the NFE1.x must be at least 1.3 bar.

When using NFE1.2, this needs to be attached to the control unit as per the terminal diagram and configured either over the App or the menu (> Accessories).

12.2. Top-up from a system separator vessel

The following must be observed if topping-up from a system separator vessel:

The system separator vessel is not monitored by Vacumat Eco (Operator's responsibility).

The smallest water level in the collection vessel must not be deeper than 1000 mm above the installation height of the Vacumat Eco unit.

13. Appendix 5: MeiFlow L MF Connector kit

The MeiFlow L MF Connector kit is used to easily connect the large distribution systems with pressure maintenance/degassing machines by means of a BigFixLock adapter plate DN150 with 2 threaded connections (1 1/4" male). The connection pipe (provided by the customer) to the respective vending machine can be connected to these sockets. The EPDM inliner is used to separate the flow rates of the machines.

Advantages

- Easy installation due to BigFixLock connection
- Predefined connection point to additional system components directly on the manifold beam.
- Additional filling and draining or sensor installation option.

	Typ	Connection	Order code
	MeiFlow L MF Connector Kit DN 150	1 1/4"	1 M66456.2

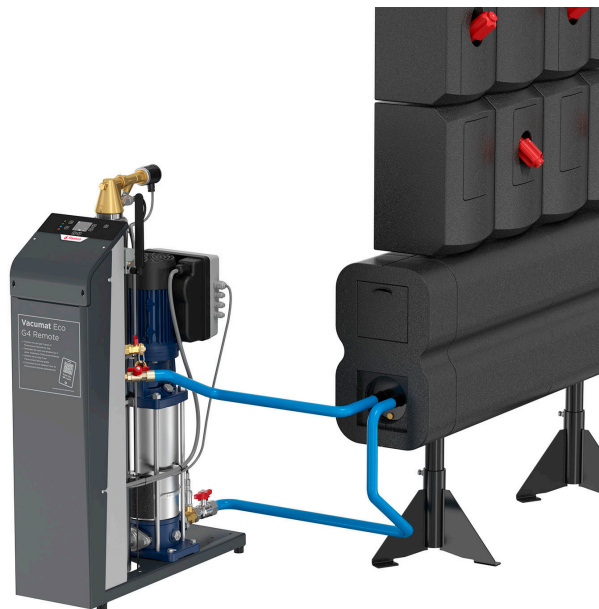

14. Appendix 6: Declaration of Conformity

Manufacturer <i>Hersteller</i>	Aalberts hydronic flow control Fort Blauwkapel 1, 1358 DB Almere, The Netherlands
Product description <i>Produktbezeichnung</i>	Degassing and top-up devices Entgasungs- und Nachspeiseautomaten
Product type <i>Produkttyp</i>	Vacumat Eco 300 (17003) Vacumat Eco 600 (17006) Vacumat Eco 900 (17009)

This declaration of conformity is issued under the sole responsibility of the manufacturer.

Die alleinige Verantwortung für die Ausstellung dieser Konformitätserklärung trägt der Hersteller.

The object of the declaration described above is in conformity with the relevant Union harmonisation legislation:

Der oben beschriebene Gegenstand der Erklärung erfüllt die einschlägigen

Harmonisierungsrechtsvorschriften der Union:

2014/53/EU	Radio Equipment Directive / Funkanlagenrichtlinie
2011/65/EU	RoHS - restriction of the use of certain hazardous substances / Beschränkung der Verwendung bestimmter gefährlicher Stoffe in Elektro- und Elektronikgeräten
2014/68/EU	Pressure Equipment Directive / Druckgeräte richtlinie

The conformity of the product described above with the provisions of the applied Directives) is demonstrated by compliance with the following Standards / regulations:

Die Übereinstimmung des bezeichneten Produkts mit den Vorschriften der angewandten

Richtlinie(n) wird nachgewiesen durch die Einhaltung folgender Normen / Vorschriften:

EN 60730-1 (2016)
EN 60730-2-6 (2016)
EN 60730-2-9 (2010)
EN 60730-2-15 (2010)
ETSI EN 301 489-1 V2.2.0 (2017-03)
ETSI EN 301 489-17 V3.2.0 (2017-03)
EN 61000-6-2 (2005) / AC (2005)
EN 61000-6-3 (2007) / A1 (2011) / AC (2012)

Aalberts hydronic flow control, *date*

Signed for and on behalf of /
 Unterzeichnet für und im
 Namen von: *M. van de Veen (Managing Director)*
 Aalberts hydronic flow control



Contact us !

We supply products for the installation industry in more than 70 countries. This is done from Flamco sales offices and via distributors who know the local market, and can give you the right advice at all times.

Aalberts hydronic flow control

The Netherlands

Postbus 30110 / 1303 AC Almere
Fort Blauwkapel 1 / 1358 AD Almere

+31 (0)36 526 2300 / nl.nfo@aalberts-hfc.com

flamco.aalberts-hfc.com